

Series LFII Residential Concealed Pendent Sprinklers, Flat Plate 4.2 K-factor

General Description

The Series LFII (TY2596) Residential Concealed Pendent Sprinklers are decorative, fast response, fusible solder sprinklers designed for use in residential occupancies such as homes, apartments, dormitories, and hotels.

The cover plate assembly conceals the sprinkler operating components above the ceiling. The flat profile of the cover plate provides the optimum aesthetically appealing sprinkler design. In addition, the concealed design of the Series LFII (TY2596) provides 1/2 inch (12,7 mm) vertical adjustment. This adjustment reduces the accuracy to which the fixed pipe drops to the sprinklers must be cut to help assure a perfect fit installation.

The Series LFII are to be used in wet pipe residential sprinkler systems for one- and two-family dwellings and mobile homes per NFPA 13D; wet pipe residential sprinkler systems for residential occupancies up to and including four stories in height per NFPA 13R; or, wet pipe sprinkler systems for the residential portions of any occupancy per NFPA 13.

The Series LFII (TY2596) has a 4.2 (60,5) K-factor that provides the required residential flow rates at reduced pressures, enabling smaller pipe sizes and water supply requirements.

The Series LFII (TY2596) has been designed with heat sensitivity and water distribution characteristics proven to help in the control of residential fires and to improve the chance for occupants to escape or be evacuated.

The Series LFII (TY2596) Residential Concealed Pendent Sprinklers are shipped with a Disposable Protective Cap. The Protective Cap is temporarily removed for installation, and then it can be replaced to help protect the sprinkler while the ceiling is being in-

stalled or finished. The tip of the Protective Cap can also be used to mark the center of the ceiling hole into plaster board, ceiling tiles, etc. by gently pushing the ceiling product against the Protective Cap. When the ceiling installation is complete the Protective Cap is removed and the Cover Plate Assembly installed.

WARNINGS

The Series LFII (TY2596) Residential Concealed Pendent Sprinklers described herein must be installed and maintained in compliance with this document, as well as with the applicable standards of the National Fire Protection Association, in addition to the standards of any other authorities having jurisdiction. Failure to do so may impair the integrity of these devices.

The owner is responsible for maintaining their fire protection system and devices in proper operating condition. The installing contractor or sprinkler manufacturer should be contacted relative to any questions.

Sprinkler/Model Identification Number

SIN TY2596

Technical Data

Approvals:
UL and C-UL Listed.

Maximum Working Pressure:
175 psi (12,1 bar)

Discharge Coefficient:
K = 4.2 GPM/psi^{1/2} (60,5 LPM/bar^{1/2})

Temperature Rating:
160°F/71°C Sprinkler with
135°F/57°C Cover Plate



Vertical Adjustment:
1/2 inch (12,7 mm)

Finishes:
Cover Plate:
Flat White, Bright White, Chrome, or
Custom

Physical Characteristics:

Body	Brass
Cap	Bronze
Saddle	Brass
Sealing Assembly	Beryllium Nickel w/ Teflon†
Soldered Link Halves	Nickel
Lever	Bronze
Compression Screw	Brass
Deflector	Copper
Guide Pin Housing	Bronze
Guide Pins	Stainless Steel
Support Cup	Steel
Cover Plate	Copper
Retainer	Brass
Cover Plate Ejection Spring	Stainless Steel

†DuPont Registered Trademark

Maximum Coverage Area ^(a) Ft. x Ft. (m x m)	Maximum Spacing Ft. (m)	Minimum Flow ^(b) and Residual Pressure For Horizontal Ceiling (Max. 2 Inch Rise for 12 Inch Run)	Minimum Flow ^(b) and Residual Pressure For Sloped Ceiling (Greater Than 2 Inch Rise Up To Max. 4 Inch Rise for 12 Inch Run)	Minimum Flow ^(b) and Residual Pressure For Sloped Ceiling (Greater Than 4 Inch Rise Up To Max. 8 Inch Rise for 12 Inch Run)
		160°F/71°C Sprinkler	160°F/71°C Sprinkler	160°F/71°C Sprinkler
12 x 12 (3,7 x 3,7)	12 (3,7)	13 GPM (49,2 LPM) 9.6 psi (0,66 bar)	18 GPM (68,1 LPM) 18.4 psi (1,27 bar)	18 GPM (68,1 LPM) 18.4 psi (1,27 bar)
14 x 14 (4,3 x 4,3)	14 (4,3)	14 GPM (53,0 LPM) 11.1 psi (0,77 bar)	18 GPM (68,1 LPM) 18.4 psi (1,27 bar)	18 GPM (68,1 LPM) 18.4 psi (1,27 bar)
16 x 16 (4,9 x 4,9)	16 (4,9)	16 GPM (60,6 LPM) 14.5 psi (1,00 bar)	18 GPM (68,1 LPM) 18.4 psi (1,27 bar)	18 GPM (68,1 LPM) 18.4 psi (1,27 bar)
18 x 18 (5,5 x 5,5)	18 (5,5)	20 GPM (75,7 LPM) 22.7 psi (1,57 bar)	20 GPM (75,7 LPM) 22.7 psi (1,57 bar)	N/A
20 x 20 (6,1 x 6,1)	20 (6,1)	24 GPM (90,8 LPM) 32.7 psi (2,25 bar)	26 GPM (98,4 LPM) 38.3 psi (2,64 bar)	N/A

(a) For coverage area dimensions less than or between those indicated, it is necessary to use the minimum required flow for the next highest coverage area for which hydraulic design criteria are stated.

(b) Requirement is based on minimum flow in GPM (LPM) from each sprinkler. The associated residual pressures are calculated using the nominal K-factor. Refer to Hydraulic Design Criteria Section for details.

TABLE A
NFPA 13D AND NFPA 13R HYDRAULIC DESIGN CRITERIA
FOR THE SERIES LFII (TY2596) RESIDENTIAL CONCEALED PENDENT SPRINKLER

Operation

When exposed to heat from a fire, the Cover Plate, which is normally soldered to the Support Cup at three points, falls away to expose the Sprinkler Assembly. At this point the Deflector supported by the Arms drops down to its operated position. The fusible link of the Sprinkler Assembly is comprised of two link halves that are soldered together with a thin layer of solder. When the rated temperature is reached, the solder melts and the two link halves separate allowing the sprinkler to activate and flow water.

Design Criteria

The Series LFII (TY2596) Residential Concealed Pendent Sprinklers are UL and C-UL Listed for installation in accordance with the following criteria.

NOTE

When conditions exist that are outside the scope of the provided criteria, refer to the Residential Sprinkler Design Guide TFP490 for the manufacturer's recommendations that may be acceptable to the Authority Having Jurisdiction.

System Type. Only wet pipe systems may be utilized.

Hydraulic Design. The minimum required sprinkler flow rate for systems designed to NFPA 13D or NFPA 13R are given in Table A as a function of temperature rating and the maximum allowable coverage areas. The sprinkler flow rate is the minimum required discharge from each of the total number of "design sprinklers" as specified in NFPA 13D or NFPA 13R.

For systems designed to NFPA 13, the number of design sprinklers is to be the four most hydraulically demanding sprinklers. The minimum required discharge from each of the four sprinklers is to be the greater of the following:

- The flow rates given in Table A for NFPA 13D and 13R as a function of temperature rating and the maximum allowable coverage area.
- A minimum discharge of 0.1 gpm/sq. ft. over the "design area" comprised of the four most hydraulically demanding sprinklers for the actual coverage areas being protected by the four sprinklers.

Obstruction To Water Distribution. Locations of sprinklers are to be in accordance with the obstruction rules of NFPA 13 for residential sprinklers.

Operational Sensitivity. The sprin-

klers are to be installed relative to the ceiling mounting surface as shown in Figure 3.

Sprinkler Spacing. The minimum spacing between sprinklers is 8 feet (2,4 m). The maximum spacing between sprinklers cannot exceed the length of the coverage area (Ref. Table A) being hydraulically calculated (e.g., maximum 12 feet for a 12 ft. x 12 ft. coverage area, or 20 feet for a 20 ft. x 20 ft. coverage area).

Installation

The Series LFII (TY2596) must be installed in accordance with the following instructions:

NOTES

Damage to the fusible Link Assembly during installation can be avoided by handling the sprinkler by the frame arms only (i.e., do not apply pressure to the fusible link Assembly).

A leak tight 1/2 inch NPT sprinkler joint should be obtained with a torque of 7 to 14 ft.lbs. (9,5 to 19,0 Nm). A maximum of 21 ft.lbs. (28,5 Nm) of torque is to be used to install sprinklers. Higher levels of torque may distort the sprinkler inlet with consequent leakage or impairment of the sprinkler.

Do not attempt to compensate for insufficient adjustment in an Escutcheon

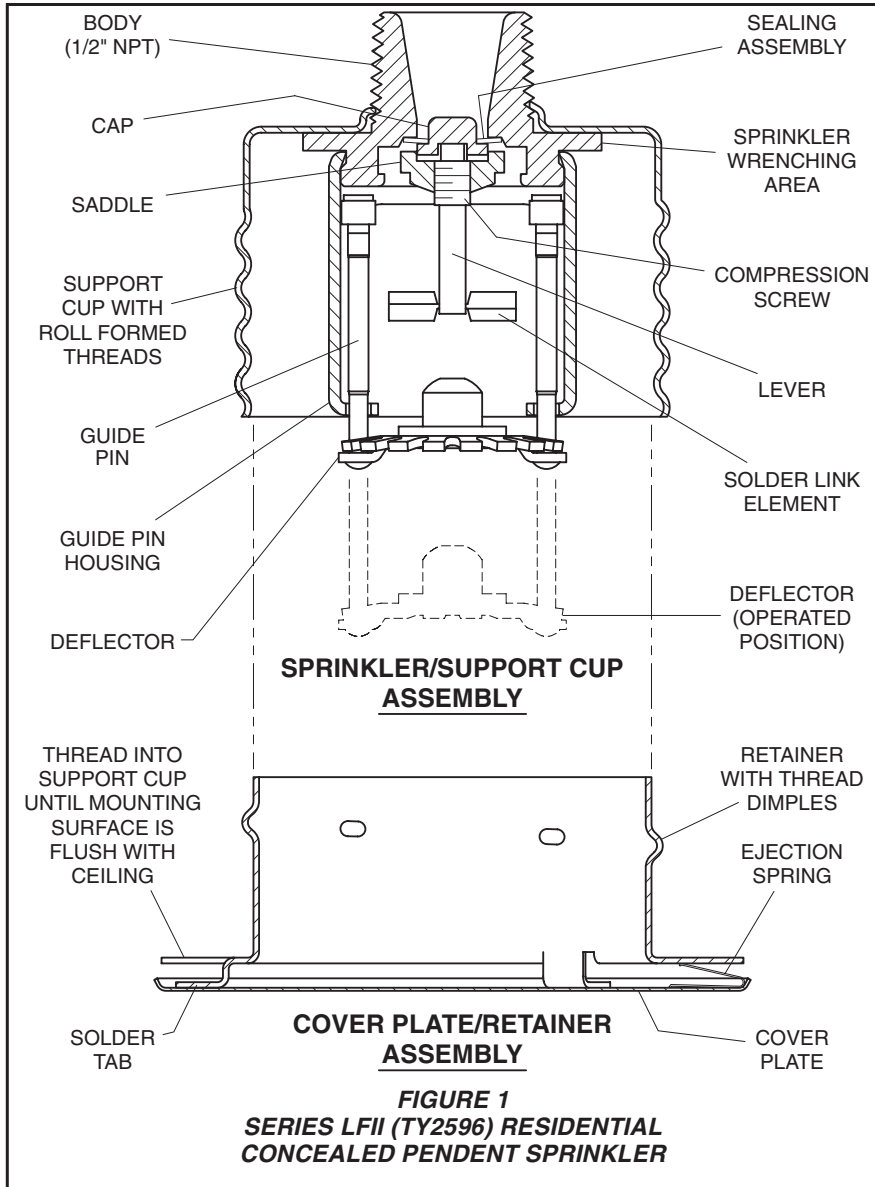

Plate by under- or over-tightening the Sprinkler. Readjust the position of the sprinkler fitting to suit.

Step 1. The sprinkler must only be installed in the pendent position and with the centerline of the sprinkler perpendicular to the mounting surface.

Step 2. Remove the Protective Cap.

Step 3. With pipe thread sealant applied to the pipe threads, and using the W-Type 18 Wrench shown in Figure 2, install and tighten the Sprinkler/Support Cup Assembly into the fitting. The W-Type 18 Wrench will accept a 1/2 inch ratchet drive.

Step 4. Replace the Protective Cap by pushing it upwards until it bottoms out against the Support Cup. The Protective Cap helps prevent damage to the Deflector and Arms during ceiling installation and/or during application of the finish coating of the ceiling. It may also be used to locate the center of the

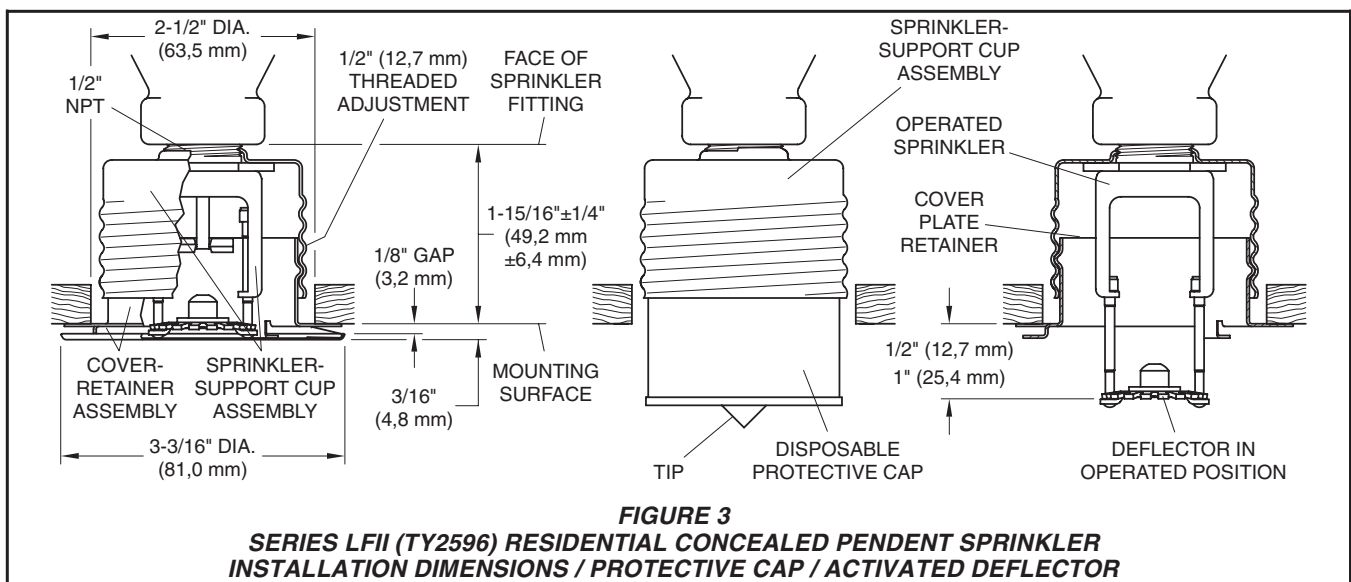
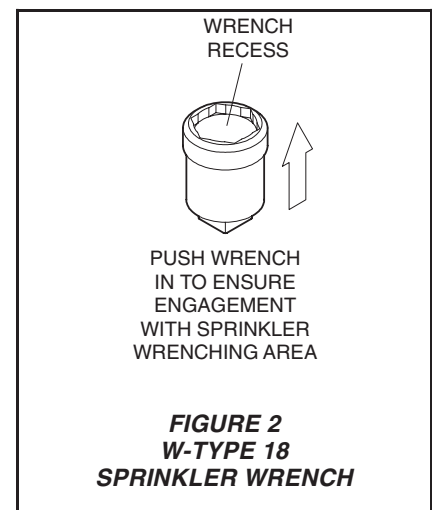

clearance hole by gently pushing the ceiling material against the center point of the Cap.

NOTE

As long as the protective Cap remains in place, the system is considered to be "Out Of Service".

Step 5. After the ceiling has been completed with the 2-1/2 inch (63 mm) diameter clearance hole and in preparation for installing the Cover Plate Assembly, remove and discard the Protective Cap, and verify that the Deflector moves up and down freely.

If the Sprinkler has been damaged and the Deflector does not move up and down freely, replace the entire Sprinkler assembly. Do not attempt to modify or repair a damaged sprinkler.

Step 6. Screw on the Cover Plate Assembly until its flange comes in contact with the ceiling.

Do not continue to screw on the Cover Plate Assembly such that it lifts a ceiling panel out of its normal position.

If the Cover Plate Assembly cannot be engaged with the Mounting Cup or the Cover Plate Assembly cannot be engaged sufficiently to contact the ceiling, the Sprinkler Fitting must be repositioned.

Care and Maintenance

The Series LFII (TY2596) must be maintained and serviced in accordance with the following instructions:

NOTES

Absence of an Escutcheon Plate may delay the sprinkler operation in a fire situation.

Before closing a fire protection system main control valve for maintenance work on the fire protection system which it controls, permission to shut down the affected fire protection system must be obtained from the proper authorities and all personnel who may be affected by this action must be notified.

Sprinklers which are found to be leaking or exhibiting visible signs of corrosion must be replaced.

Automatic sprinklers must never be painted, plated, coated, or otherwise altered after leaving the factory. Modified or over heated sprinklers must be replaced.

Care must be exercised to avoid damage - before, during, and after installation. Sprinklers damaged by dropping, striking, wrench twist/slippage, or the like, must be replaced.

The owner is responsible for the inspection, testing, and maintenance of their fire protection system and devices in compliance with this document, as well as with the applicable standards of the National Fire Protection Association (e.g., NFPA 25), in addition to the standards of any other authorities having jurisdiction. The installing contractor or sprinkler manufacturer should be contacted relative to any questions.

NOTE

The owner must assure that the sprinklers are not used for hanging of any objects and that the sprinklers are only cleaned by means of gently dusting with a feather duster; otherwise, non-operation in the event of a fire or inadvertent operation may result.

It is recommended that automatic sprinkler systems be inspected, tested, and maintained by a qualified Inspection Service.

Limited Warranty

Products manufactured by Tyco Fire Products are warranted solely to the original Buyer for ten (10) years against defects in material and workmanship when paid for and properly installed and maintained under normal use and service. This warranty will expire ten (10) years from date of shipment by Tyco Fire Products. No warranty is given for products or components manufactured by companies not affiliated by ownership with Tyco Fire Products or for products and components which have been subject to misuse, improper installation, corrosion, or which have not been installed, maintained, modified or repaired in accordance with applicable Standards of the National Fire Protection Association, and/or the standards of any other Authorities Having Jurisdiction. Materials found by Tyco Fire Products to be defective shall be either repaired or replaced, at Tyco Fire Products' sole option. Tyco Fire Products neither assumes, nor authorizes any person to assume for it, any other obligation in connection with the sale of products or parts of products. Tyco Fire Products shall not be responsible for sprinkler system design errors or inaccurate or incomplete information supplied by Buyer or Buyer's representatives.

IN NO EVENT SHALL TYCO FIRE PRODUCTS BE LIABLE, IN CONTRACT, TORT, STRICT LIABILITY OR

UNDER ANY OTHER LEGAL THEORY, FOR INCIDENTAL, INDIRECT, SPECIAL OR CONSEQUENTIAL DAMAGES, INCLUDING BUT NOT LIMITED TO LABOR CHARGES, REGARDLESS OF WHETHER TYCO FIRE PRODUCTS WAS INFORMED ABOUT THE POSSIBILITY OF SUCH DAMAGES, AND IN NO EVENT SHALL TYCO FIRE PRODUCTS' LIABILITY EXCEED AN AMOUNT EQUAL TO THE SALES PRICE.

THE FOREGOING WARRANTY IS MADE IN LIEU OF ANY AND ALL OTHER WARRANTIES EXPRESS OR IMPLIED, INCLUDING WARRANTIES OF MERCHANTABILITY AND FITNESS FOR A PARTICULAR PURPOSE.

Ordering Procedure

When placing an order, indicate the full product name. Contact your local distributor for availability..

Sprinkler Assembly:

Series LFII (TY2596), K=4.2, Residential Concealed Pendent Sprinkler without Cover Plate Assembly, P/N 51-122-1-160.

Cover Plate Assembly:

Cover Plate Assembly having a (specify) finish for the Series LFII (TY2596), K=4.2, Residential Concealed Pendent Sprinkler, P/N (specify).

Chrome	P/N 56-122-9-135
Off White	P/N 56-122-0-135
Bright White.....	P/N 56-122-4-135
Flat White	P/N 56-122-5-135
Custom	P/N 56-122-X-135

Sprinkler Wrench:

Specify: W-Type 18 Sprinkler Wrench, P/N 56-000-1-265.